

Usability in ERP (Single and Multiple Document Interface) Application Environments

Mazhar Sadiq & Antti Pirhonen

Department of Computer Science and Information System
University of Jyväskylä
Finland

Abstract

The usability of complex information systems, like enterprise resource planning (ERP), is the next frontier, as the trend becomes more and more adopted in the industrial working environment. In complex information systems, the traditional usability criteria of learn ability, effectiveness and efficiency have never lost their importance, even though the focus of research appears to have shifted for the consumer product. This study based on 110 responses attempt to highlight the usability issues in ERP single document interface (SDI) and multiple document interface (MDI) application environments. It also investigates the effect of negative user experience, such as 'confusion', on learnability, effectiveness and efficiency. The results indicate that the SDI is better for providing end-user usability in ERP. The results suggested that in SDI application environments, end-user confusion with the ERP system directly affected learnability but not effectiveness and efficiency. In MDI application environments, the results suggested that end-user confusion with the ERP system directly affected learnability, effectiveness and efficiency.

Keywords: Usability; Enterprise Resource Planning; Single Document Interface (SDI) Window; Multiple Document Interface (MDI) Window; Learnability; Effectiveness; Efficiency

1. Introduction

The history of the concept of usability arises from industrial settings and Taylorian ideals to reconcile industrial machinery with its human operator (e.g., Card et. al, 1983), that is, the whole, consisting of machines and humans, should work effectively. Usability was introduced as a means to understand the relationship between human beings and technical devices. However, when the focus of human-computer studies gradually shifted to consumer products, the role of usability changed. In industrial settings, usability was considered a means for accurate, effective performance; in the area of consumer products, that kind of criterion has value only if the consumer prioritises it. The most important aspect was not measurable efficiency but the overall experience of using the application. In marketing consumer products, the primary aim is to make the consumer consume, not to perform a given task effectively.

In practice, this has led to the seeking of entertainment rather than satisfaction of some fundamental human needs. Even if there has been a great deal of progress in the usability of consumer products during the last few years, usability is only valued in that context if it makes people consume more. Therefore, more subjective criteria, such as user experience (UX), have gained popularity among human-computer researchers, along with the expansion of computational consumer products. UX can be describe as the "overall experience and satisfaction a user has when using a product or system" (Lumsden, 2008).

In complex information systems, subjective and possibly biased qualities like UX may play an important role. At least it is difficult to see what harm would be caused if a user of an industrial application like enterprise resource planning (ERP) finds the usage satisfying, enjoyable, fun, entertaining and motivating. It is also interesting to see whether an undesirable user experience, such as 'confusion' with the user interfaces (SDI or MDI), would also affect typical usability attributes such as learnability, effectiveness and efficiency. There are mainly two types of methods for organising the graphic user interface window: single document interface (SDI) and multiple document interface (MDI).

In SDI, the graphical user interfaces are organised in such a way that each individual window is handled separately by the manager of the operating system’s window (Wikipedia, 2014). In MDI, the information can be presented simultaneously in adjacent windows, and the system often allows child windows to be embedded in other windows (Galitz, 2007). For example, to process the order, you could collect the customer name and account number in one window and the inventory details in a second or third window (Galitz, 2007). The goal of this article is to highlight usability issues in ERP SDI and MDI application environments. This study also investigated the effects of negative user experience, such as ‘confusion’, on learnability, effectiveness and efficiency. The next section discusses the research methodology that is based on the survey of 110 end-users from two organizations. This is followed by the results, comparison and the conclusion.

2. Research Methodology

To approach this research, we used survey methodology. Two organisations from the Pakistan were contacted for collecting primary data from the end-users. The main instrument for collecting the data questionnaire comprising the following three questions:

1. Is ERP (single and multiple document window) application environment same for providing end-users usability?
2. Does end-user confusion with the user interfaces in an ERP SDI environment affect learnability, effectiveness and efficiency?
3. Does end-user confusion with the user interfaces in an ERP MDI environment affect learnability, effectiveness and efficiency?

The Overall Research Methodology can be seen in Figure 1.

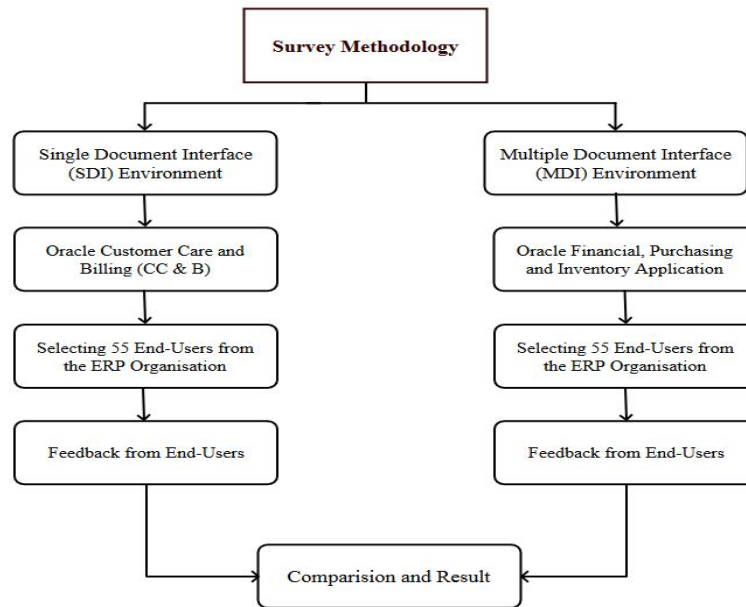

Figure 1: Research Methodology

2.1 End-User Detail

The 110 respondents for this research were full-time employees working in two organisations that implement ERP system. We divided the respondents into two groups. This division is based on user interface adoption methodology. The first group, which consisted of 55 respondents, were working on SDI applications like Oracle Utilities’ customer care and billing (CC&B). This application utilises the browser base user interface (BUI), which is the combination of HTML and JavaScript (Oracle,2010). The second group consisted of another 55 respondents who were working on MDI applications like Oracle’s finance, inventory and order management. These three types of applications utilise form base user interfaces to present information. Most of the forms have several windows associated with them (Oracle, 2009). Out of 110 respondents, 20 were having the experience with both type of applications. The details of the respondents are shown in Table 1.

Table 1: End-user Detail

UI Methodology	Oracle ERP system	Industry Type	Respondents	Experience
SDI	CC & B	Distribution	55	0–6
MDI	Financial, Purchasing, Inventory	Manufacturing	55	0–6

2.2 Questionnaire Items

The questionnaire consisted of four parts. The first part involved demographic questions designed to collect information about the respondents, their organisation, age, gender, type of ERP system used and their experience with the ERP system. The second part consisted of items measuring confusion with the ERP system. The third part consisted of items measuring three usability attributes: learnability, effectiveness and efficiency. A seven-point Likert-type scale was used to collect feedback from the 110 respondents. The measurement scale starts at 1 (strongly disagree) and goes to 7 (strongly agree). The entire instrument is shown in Appendix A.

3. Research Results

This section presents the results of research questions 2 and 3. The results of research question 1 are discussed in section 4. For the seven items of the scale, descriptive statistics were investigated using mean, standard deviation, skewness and kurtosis. The psychometric properties of the instrument were evaluated using Cronbach's alpha, which measures internal consistency.

3.1 Results from the SDI Application Environment

A total of 55 responses were obtained from the end-users who were working on the Oracle Utilities' CC&B application. The results are shown in Table 2. The mean value for learnability is 2.7, and the standard deviation is .58. The overall mean value for effectiveness is 5.9, and the standard deviation .74; for efficiency, it is 5.5 and .49; for confusion, it is 2.9 and .52. Some values for skewness and kurtosis are positive and others are in negative, but the overall data achieved in this process are in the normal distribution range. The normal values range is between -1 and 1 (Joo et. al., 2011). All of the alpha values are above .5, which is acceptable for this kind of research.

Table 2: Results from the SDI application environment

Attributes	Item	Mean	Standard Deviation	Skewness	Kurtosis	Cronbach's alpha
Learnability	Lrn1	2.7	.58	-1.0	.37	.59
Effectiveness	Eft1	5.9	.74	-1.0	.96	.68
	Eft2					
Efficiency	Efy1	5.5	.49	.85	-.89	.72
	Efy2					
	Efy3					
Confusion	Cnf1	2.9	.52	.35	-.25	.54

3.11 End-User Confusion and its Effect on Usability Attributes

To determine the answers to research question 2, a correlation analysis was performed. The results are shown in Figure 2. Positive correlations are shown with a plus (+) green sign, while negative correlations are shown with a minus (-) red sign. The results show that in the SDI application environment, end-user confusion with the ERP system directly affected learnability with the system. This is negatively correlated with effectiveness (-.13) and efficiency (-.11). These results are interesting and provide further research opportunities for ERP SDI application environment.

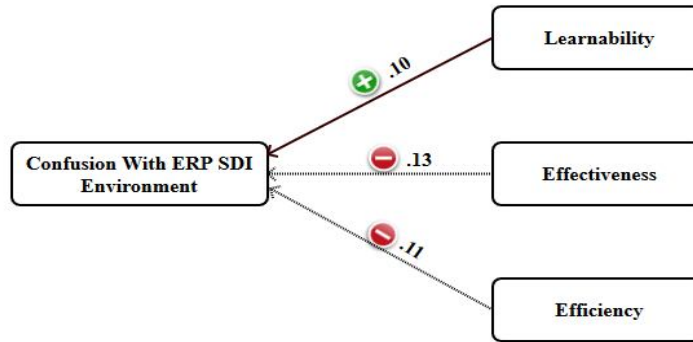

Figure 2. Confusion with the ERP SDI Environment

3.2 Results from the MDI Application Environment

A total of 55 responses were obtained from the end-users who were working on the Oracle financials, purchasing and inventory modules. The results are shown in Table 3. The overall mean value for learnability is 1.4, and the standard deviation .69; for effectiveness it is 5.7 and .7; for efficiency it is 2.0 and .44; for confusion it is 5.5 and .7. All the skewness, kurtosis and alpha values are in the required range.

Table 3: Results from the MDI Application Environment

Attributes	Item	Mean	Standard Deviation	Skewness	Kurtosis	Cronbach’s alpha
Learnability	Lrn1	1.4	.69	.43	-0.9	.62
Effectiveness	Eft1	5.7	.7	1.0	.23	.54
	Eft2					
Efficiency	Efy1	2.0	.44	.32	-0.8	.67
	Efy2					
	Efy3					
Confusion	Cnf1	5.5	.7	.83	.17	.59

3.3 End-Users Confusion and its Effect on Usability Attributes

Figure3 shows the results of the correlation analysis. The results are different than those shown in the SDI application environment. In the MDI application environment, end-user confusion with the ERP system directly affected learnability, effectiveness and efficiency with the ERP system. The positively correlated values are .22 for learnability, .15 for effectiveness and .31 for efficiency.

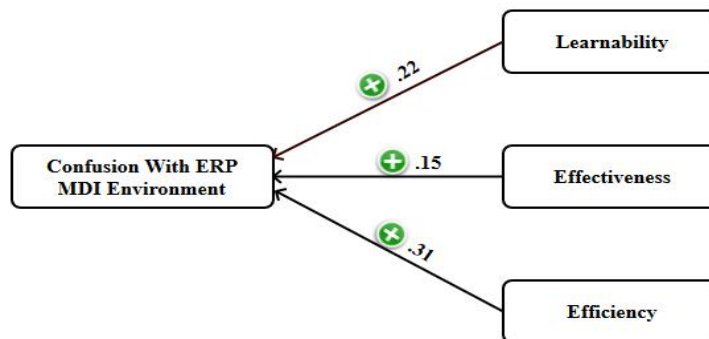

Figure 3: Confusion with the ERP MDI Environment

4. Usability Issues in ERP SDI and MDI Application Environment

The overall usability results from the ERPSDI and MDI application environments are shown in the end-user interaction model in Figure 4. The results are based on four attributes: learnability, effectiveness, efficiency and confusion. The end-user has the goal of completing his or her tasks using an ERP application. He or she interacts with the ERP application, which, in this study, is Oracle’s customer care and billing, financial, purchasing and inventory modules.

The assumed usability goals of the ERP are that end-users should not have to spend a great deal of time learning to use the ERP system, they should be able to complete their tasks in effective and efficient ways, and they should not be confused when using the ERP system. If we compare the overall results then, the SDI is better in term of usability as compared to MDI. In case of learnability, the mean value is 2.7 for SDI and 1.4 for MDI, and the difference between the two values is 1.3. For effectiveness, the mean value is 5.9 for SDI and 5.7 for MDI, and the difference between the two values is .2; for efficiency, it is 5.5 and 2.0, and the difference is 3.5; for confusion, it is 2.9 and 5.5, and the difference is 2.6.

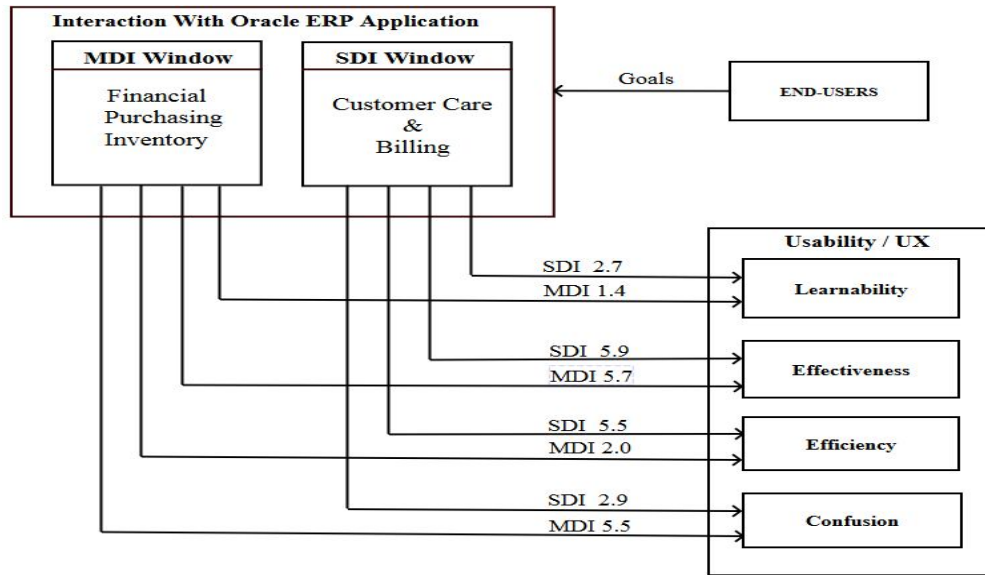

Figure 4: End-User Interaction Model

5. Conclusion

This research examined usability issues in ERP SDI and MDI application environments. A conceptual model presenting the usability attributes of learnability, effectiveness, efficiency and confusion was developed. The most noticeable aspects of this model are the differences in the values for confusion and efficiency with the ERP. The overall result shows that for end-users, a SDI window was better for providing usability in the ERP system. Another noticeable aspect of the results was that in the SDI application environment, end-user confusion with the ERP system only affected learnability and not effectiveness and efficiency. However, in the MDI application environment, end-user confusion with the ERP system directly affected learnability, effectiveness and efficiency with the system.

References

- Al-Mashari, M., Al-Mudimigh, A., & Zairi, M. (2003). Enterprise Resource Planning: a taxonomy of critical factors. *European Journal of Operational Research*, 146, 352–364.
- Aloini, D., Dulmin, R., & Mininno, V. (2007). Risk management in ERP project introduction: Review of literature. *Information & Management*, vol. 44, pp. 547-567.
- Amoako-Gyampah, Kwasi. (2007). Perceived usefulness, user involvement and behavioral intention: an empirical study of ERP implementation." *Computers in Human Behavior* 23.3; 1232-1248.
- Card, S. K., Moran, T. P., & Newell, A. (1983). *The psychology of human-computer interaction*. Hillsdale, NJ: Erlbaum.
- Davis, R. D. (1989). Perceived usefulness, perceived ease of use, and user acceptance of technology. *MIS Quarterly*, 13(3), 319–340.
- F. Calisir., & F. Calisir. (2004). The relation of interface usability characteristics, perceived usefulness, and perceived ease of use to end-user satisfaction with enterprise resource planning (ERP) systems, *Computers in Human Behavior* 20 (4); 505–515.

- Galitz, W.O. (2007). Essential guide to user interface design: An introduction to GUI design principles and techniques. New York: Wiley.
- Garača, Željko. (2011). Factors related to the intended use of ERP systems. Management-Journal of Contemporary Management Issues 2: 23-42.
- Gupta, A. (2000). Enterprise resource planning: the emerging organizational value systems. Industrial Management & Data Systems, 100(3), 114–118.
- Joo, S., Lin, S., & Lu, K. (2011). A Usability Evaluation Model for Academic Library Websites: Efficiency, Effectiveness and Learnability. Journal of Library and Information Studies, 9(2), 11-26.
- Oracle. (2010). Oracle Utilities Customer Care and Billing, Operations and Configuration Guide, Ver 2.3.1, E18371-01.
- Lumsden, J. (2008). Handbook of Research on User Interface Design and Evaluation for Mobile Technology. IGI Global.
- Oracle. (2009). Oracle E-Business Suite User Interface Standards for Forms-Based Products, Release 12.1, Part No. E12900-03.
- Sadiq, M., & Pirhonen, A. (2012). Computer literacy training is an important factor to improve usability in ERP applications. IADIS International conference of Interface and Human Computer Interaction, pp. 245-250.
- Wikipedia, Graphical user interface. (2014). http://en.wikipedia.org/wiki/Single_document_interface (Accessed 08.06.14).

Appendix A. Questionnaire Items

Part I: Demography Questions

- What is your age?
 What is your gender?
 What type of ERP system are you using?
 What is your work experience with the ERP system?

Part II: Confusion with the ERP User Interface

Scale:

1= Strongly disagree, 2 = Somewhat disagree, 3 = Disagree, 4 = Neutral, 5 = Agree, 6 = Somewhat agree, 7 = Strongly agree

Question Item:

Cnf1: The user interface of this ERP application is confusing.

Part III: Learn ability, Effectiveness and Efficiency

Scale:

1= Strongly disagree, 2 = Somewhat disagree, 3 = Disagree, 4 = Neutral, 5 = Agree, 6 = Somewhat agree, 7 = Strongly agree

Learn ability

Question Item:

Lrn1: It is easy to learn how to use this ERP application.

Effectiveness

Question Items:

- Efy1: It is easy to find the required information by giving different search criteria.
 Efy2: This ERP application effectively helps me complete my job task.

Efficiency

Question Items:

- Eft1: The ERP application requires one simple step to go from the main menu to a higher level window.
 Eft2: The ERP application requires only one simple step to return back to the main menu.
 Eft3: The ERP application requires minimal steps for submitting and viewing the reports output.